

SJ4740 E

ELECTRIC SCISSORS



STANDARD FEATURES

- Drivable at full height
- Variable speed, dual rear wheel electric drive
- Dual holding brakes
- SKYCODED™ Color coded and numbered wiring system
- On-board visual interface with diagnostic capabilities
- Shroud style, impact resistant composite control box with extended cable
- Low battery indicator light on control box
- Proportional controls for drive & lift functions
- 3' (0.90 m) Roll out extension deck
- 24V DC Power source
- 110V AC Outlet on platform with GFI
- Low voltage battery protection
- 25% Gradeability
- Solid rubber, non-marking tires
- Pothole protection system
- Tilt alarm with drive & lift cut-out (3.5° x 1.5°)
- All motion audible alarm
- 28 mph (12.5 m/s) Wind rating to 24' (7.3 m)
- Lanyard attachment points
- Operator horn
- Forklift pockets and tie down / lift lugs
- Overload sensing system
- Fold down hinged railing system
- Half height spring hinged entry gate
- Telematics ready
- 2-Year Gold Leaf Warranty (5-year structural warranty)



- 16% operational carbon saving compared to previous model



- Up to 20% improvement in duty cycle



- ZERO emissions



- <70 dB inherently quiet machine operation (excl. alarms)
- White noise/broadband alarms - *optional*



- 90% recyclable (by weight)



- 60% less hydraulic connections – reduces leak potential
- ECOTRAY leak containment - *optional*
- Bio-degradeable hydraulic oil - *optional*



- Telematics – remote diagnostics reduces site visits (operational carbon foot print)



SJ4740 E ELECTRIC SCISSORS

Dimensions	SJ4740 E
A Work Height	44' 11" (13.69 m)
B Raised Platform Height	38' 11" (11.86 m)
C Lowered Platform Height	56" (1.41 m)
D Overall Width	47" (1.20 m)
E Overall Length	95.2" (2.41 m)
F Stowed Height (Rails Up)	99.5" (2.53 m)
G Stowed Height (Rails Down)	79.8" (2.03 m)
H Platform Width (Inside Dimension)	42" (1.06 m)
I Platform Length (Inside Dimension)	86" (2.19 m)
Specifications	SJ4740 E
Extension Deck (Roll Out)	3' (0.91 m)
Ground Clearance (Pothole Raised)	4.5" (11.4 cm)
Ground Clearance (Pothole Deployed)	0.50" (1.3 cm)
Wheelbase	73" (1.85 m)
Weight	6,470 lbs (2,935 kg)
Gradeability	25%
Turning Radius (Inside)	31" (0.79 m)
Turning Radius (Outside)	110" (2.78 m)
Lift Time (With Rated Load)	88 sec
Lower time (With Rated Load)	53 sec
Drive Speed (Stowed)	2.0 mph (3.2 km/h)
Drive Speed (Raised)	0.5 mph (0.8 km/h)
Maximum Drive Height	Full Height
Capacity (Overall)	770 lbs (350 kg)
Distributed Capacity (Main Platform)	505 lbs (229 kg)
Distributed Capacity (Extension Deck)	265 lbs (120 kg)
Local Floor Load (With Rated Load)	139 psi (956 kPa)
Overall Floor Load (With Rated Load)	233 psf (1,137 kg/m ²)
Maximum # of persons at 0 mph (0 m/s) wind rating	3
Maximum # of persons up to 28 mph (12.5 m/s) wind rating	1 (Up to 24' (7.3 m))
Tire Type	Solid, N/M
Tire Size	16 x 5 x 12

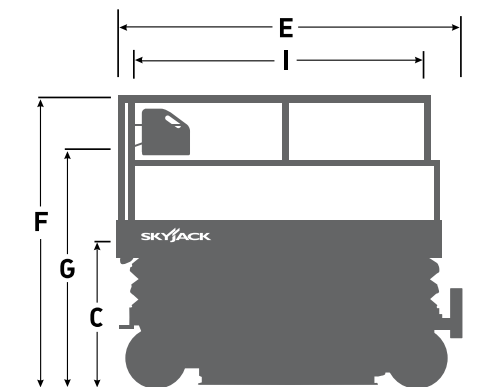
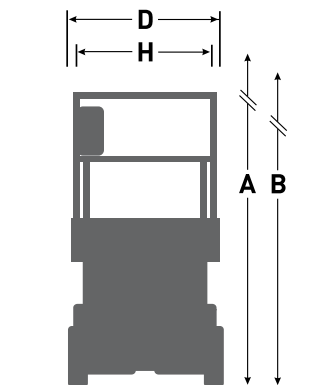

ACCESSORYZERS[†]

- Light duty pipe rack
- Heavy duty pipe rack
- Board carrier
- Tool caddy
- ECOTRAY leak containment system
- Secondary Guarding Lift Enable (SGLE)
- Perimeter lights (Cannot be combined with dual flashing lights)

OPTIONS[†]

- Flashing light
- Dual flashing lights
- White noise alarm
- AGM Batteries
- Lockable swingout trays
- Full height spring hinged entry gate
- Bio oil
- Non-destructive testing
- ELEVATE telematics (1-year, 3-year or 5-year plans available)
- Extended warranty (3-year or 5-year plans available)

